



CHARGING STATIONS

MyBox Plus

Installation manual | Users guide

Content

Basic information

Introduction	4
Product overview	5
Functions	6
Technical specifications	7

Safety

Important safety instructions	8
-------------------------------	---

Installation

Preparation for installation	9
Installation manual	10
Charging station settings	13
Charging station configuration	14

Daily use and operation

How it charges	15
Application and local interface	16
Light signaling	17

Others

QR code of the charging station	19
---------------------------------	----

IMPORTANT: Read the manual carefully before use and keep it for future reference.

Introduction

This product is designed exclusively for charging electric vehicles. The product must only be used with a charging cable according to IEC 62196.

The product must be firmly mounted on the wall according to the instructions in the installation section of the manual. The structure for placing the product must have sufficient load capacity. Alternatively, the MyBox stand supplied for the PLUS station, including installation instructions, can be used for mounting.

The product may only be used under approved operating parameters and under specified environmental conditions.

Uses other than those listed here are not permitted.

Used symbols:



ELECTRICAL RISKS

Observe the appropriate safety precautions when carrying out electrical installation inside the equipment. The equipment must be disconnected from all power sources during installation.



ATTENTION

It signals that property damage can occur if adequate precautions are not taken.

Product overview



Front panel

It provides signaling, identification and also protection of the electrical part of the device against environmental influences.

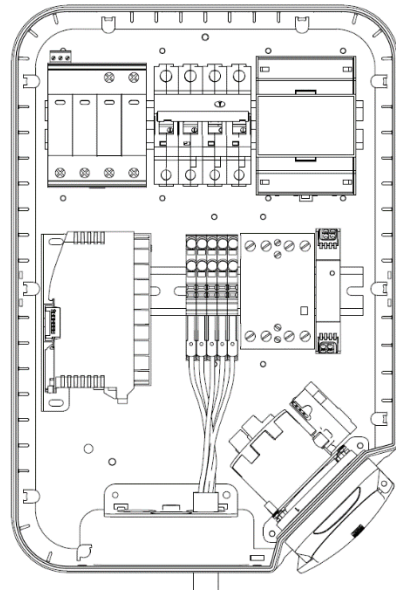

Body

It is used for mounting on a solid base and connection to the mains. It contains all the electronic components needed for vehicle charging.

Functions

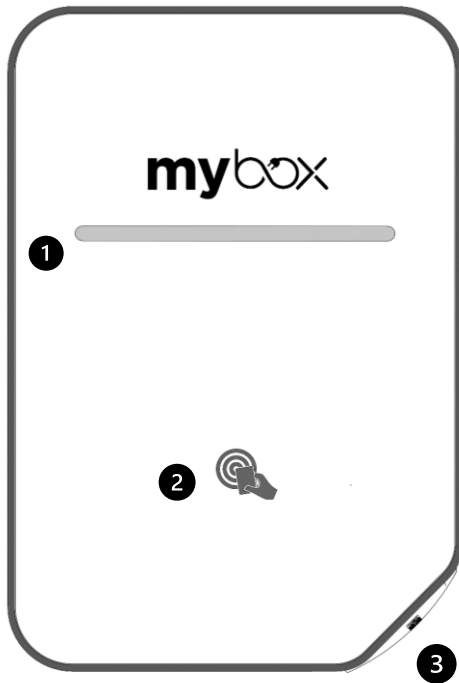

1. Smart LED signalization: The light bar informs about the status of the charging station during the charging process and also in service mode for installation purposes. For more information on the color indication, see "Light indication" on page 17.

2. Area RFID: The charging station can be equipped with an RFID reader, which allows identification of users and also secure start or end of the charging process using an RFID tag (card, chip, key fob, etc.). For more information, please visit our website at www.mybox.eco/support.

3. Socket or integrated charging cable Type 2: Any type of electric vehicle that is equipped with a Type 2 input socket (Mennekes) can be charged using a Type 2 socket or universal charging cable. Both variants are tightly integrated into the charging station.

Technical specification

Basic information

Dimensions (W x H x D)	280 x 410 x 128 mm
Material	tempered glass, ABS plastic, steel
Operating temperature	-30 °C to +50 °C
Status indication	colored LED indicator
Masses	8,5 – 13,5 kg

Charging

Maximum output power	1,4-22 kW
Connecting point	1x integrated type 2 charging cable (IEC 62196-2) or charging socket type 2
Number of phases	1 or 3
Voltage:	3 x 400 V AC/ 230 V AC ($\pm 10\%$) (3P + N + PE)
Maximum input current	3 x 32 A
Network frequency:	50/60 Hz

Installation

Network types TN, IT or TT (detected automatically)
Installation circuit breaker: max. 40 A overload protection.
Short-circuit current at the charging point (I_{kMax}) must not exceed 10 kA.
If required by the installation method, type A earth fault protection can be used for the circuit.
Conductor cross-section: up to 10 mm² (one cable)
Cable diameter: 6-10 mm

Connectivity

Ethernet RJ45 (according to configuration)
WiFi 2.4 GHz b/g/n
Modbus / RTU / RS485
RFID / NFC reader (ISO-14443 A&B) Mifare, Legic, 1-wire
Serial TTL
MQTT broker / client
OCPP 1.6

Protection

Integrated overload protection according to EN IEC 61851-1:2019 (according to configuration)

Sensor RCM 6 mA DC leakage detector 6 mA DC

Level of protection:
IP54/IK10 (unplugged)
IP54/IK10 (plugged)

Impact resistance: IK10

Important safety instructions



Before use, carefully read all instructions to ensure proper installation of the charging station.

This charging station is designed for indoor and outdoor installation. The device must be installed safely. Adequate protection must be provided during the installation process, in accordance with all installation conditions.

- The charging station must not be installed in places with explosion hazard.
- Do not handle or repair the unit when the unit is energized.
- Do not install the charging station where it could be damaged by falling objects.
- Only trained and qualified personnel should handle low-voltage electrical components inside the unit.
- The surface on which the charging station is placed must be able to withstand mechanical forces.
- The installation must be inspected annually by a qualified technician.
- Remove from service and have serviced any defective part that poses a danger to the user (broken plugs, caps that cannot be closed...).
- Only use the unit for charging electric vehicles according to IEC 61851.
- In case of unauthorized modification of the control unit, ELEXIM, a.s. will not be liable for the charging station and its warranty will be void.
- Only use spare parts supplied by ELEXIM, a.s. for service.
- Strictly observe the electrical safety regulations applicable in your country.
- Do not use this product if the EV cover or connector is broken, cracked, open or shows any other sign of damage.
- The equipment must be disconnected from any power source during commissioning.
- The charging station may only be wired by a person qualified in electrical engineering according to Decree No. 194/2022 Coll., who is also thoroughly familiar with this manual and the functions of the device.
- After wiring, the internal part of the device is an area that is accessible only to maintenance/service or to a person qualified in electrical engineering according to Decree No. 194/2022 and following.
- The device is intended for permanent connection.

Preparation for installation

Place of installation

The station must be fixed to a solid straight wall or a straight column (material brick, concrete, block), where the minimum distances from obstacles must be observed, see picture below.

Select a suitable location for mounting the charging station that meets the specified requirements.

For standard mounting of the charging station, use the supplied screws and dowels from the installation kit (in case of non-standard mounting, the corresponding mounting material must be used).

Minimum distances from obstacles

The following must be available for the installation of the equipment and a certain amount of space to facilitate use, maintenance and compliance with safety regulations.

When installing the equipment, observe the specified minimum distances for maintenance and safety.

All dimensions in the drawings are given in millimeters.

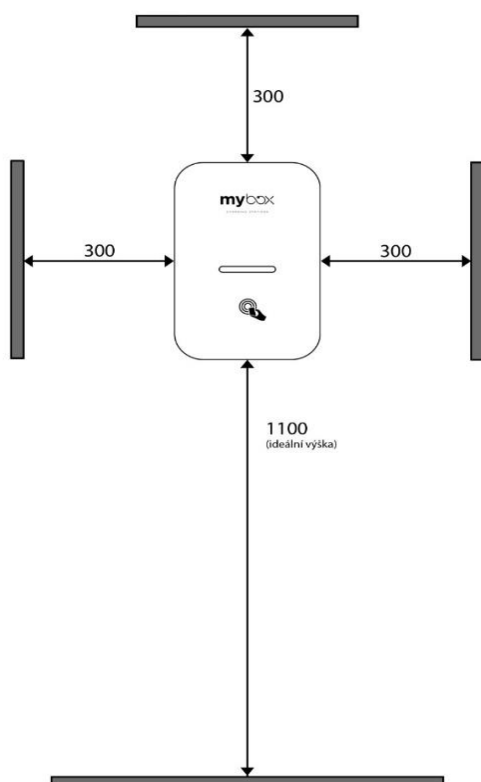

Switchboard equipment

Circuit breaker 3-pole, characteristics B, 32 A

Current protector Type A 4-pole characteristics A, 40 A

Supply cable CYKY 5x 6-10 mm²
The cable can be fed into the station from the rear or from the bottom

Tools and equipment

Drill machine drill 8 mm
Screwdriver Phillips

Consumables (included in the package)

Insulation pads 4ks, 5x19
Dowel pins 4ks, 8 mm
Screws 4ks, 4x40 mm

Installation guide



ATTENTION! This product may only be installed, repaired or serviced by an authorized electrician. All relevant local, regional and national electrical installation regulations must be observed and respected.



WARNING! Turn off the power before starting the installation. Perform installation with caution and carefully follow the instructions.



In addition to the instructions in the installation manual/guide, we recommend watching the installation videos available on our website mybox.eco

1 Opening

1. Unscrew the Allen screws from the underside.
2. Remove the front panel of the station by tilting it upwards from the underside.

The connector for the LED panel is factory disconnected (or disconnect it from the LED panel).

ATTENTION! The front panel is made of tempered glass, careless handling can cause damage!

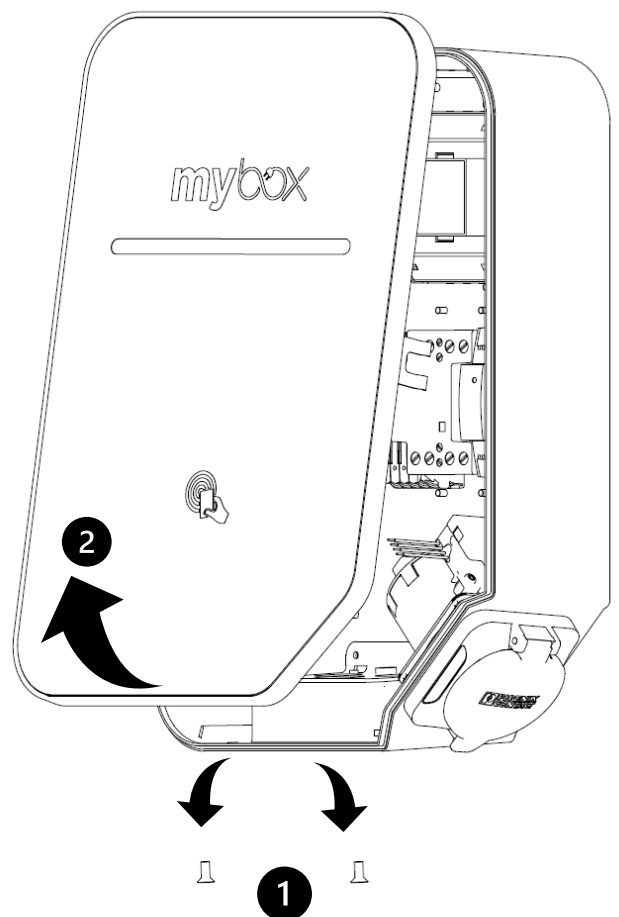

2 Assembly

1. Remove the mounting plate using the two locking screws.
2. Attach the charging station mounting plate to a wall or structure with sufficient load capacity using 4 screws.
3. Use suitable dowels for mounting and observe the recommended mounting height.
4. Mount the charging station on the attached mounting plate.
5. Using the locking screws, re-secure the charging station to the mounting plate.

ATTENTION! Use suitable anchoring material. Due to the weight of the charging station and future cable handling. Always use all 4 holes for installation!

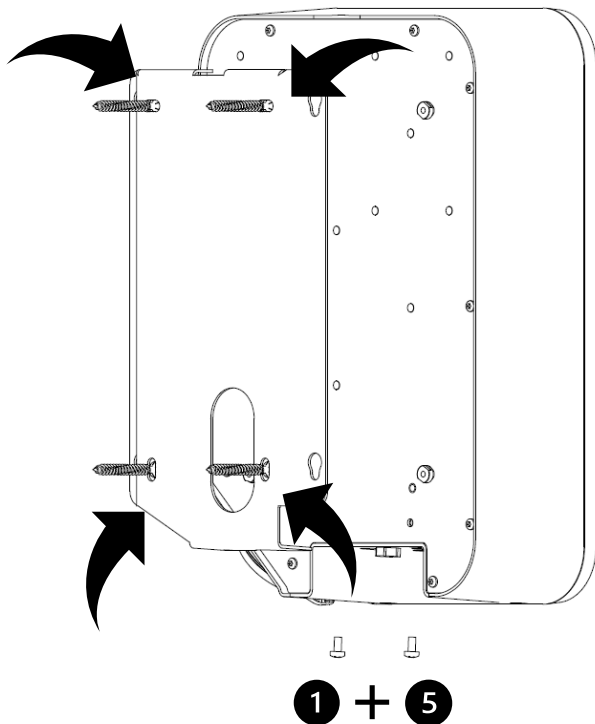

3 Preparation

1. Inlet from the underside
The station is ready for this option from the factory. An M25 cable gland is provided for the installation of the supply cable and an M16 gland for the communication cable with the dynamic power management evaluation unit.
2. Rear inlet
In this case, it is necessary to interchange the pins (from the bottom side) and the plugs (from the back side) to ensure that the station is leak-proof.

ATTENTION! Grommets must be installed inside the station.

For the variant without dynamic cable control, it is only the M25 grommet and M16 plug.

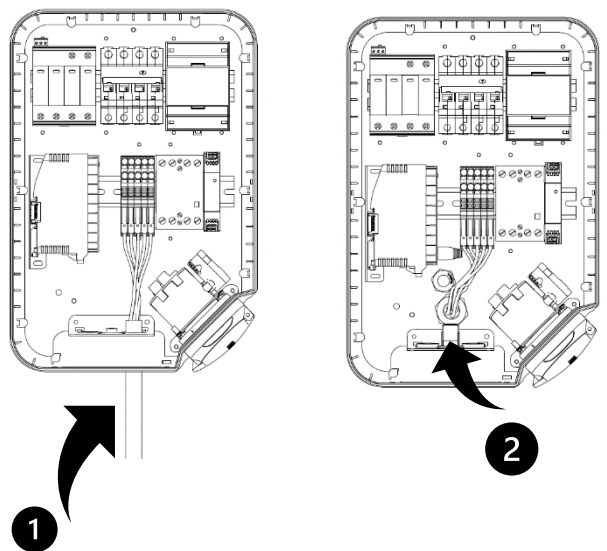

4 Wiring

1. Strip the individual vires by 13-15 mm. If the cable has salted conductors, it is recommended to use grommets. Use suitable tools to crimp them.
2. Connect the supply wires to the appropriate terminals according to the drawings below.

ATTENTION! Before turning on the power, make sure and check that all wires are connected correctly and tightening of the glands and plugs.

TN/TT 3 phase
230/400 V

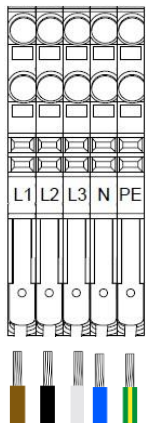

TN 1 phase
230 V

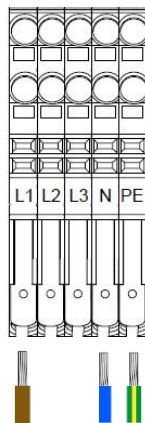

NOTICE! It is recommended to follow the existing colour marking of conductors used in the installation.

Depending on national standards, cable colours may differ from those shown. The illustrations in this manual follow the Czech national standards.

5 Closing

1. Connect the connector to the LED panel.
2. Connect the connector for the RFID reader (if the charging station is equipped with an identification)
3. Replace the front panel in the reverse way as for opening.
4. Screw the locking screws at the bottom of the charging station to secure the front cover.

ATTENTION! Check that the Allen screws on the bottom of the charging station are tightened correctly.

The tightening torque is 4Nm.

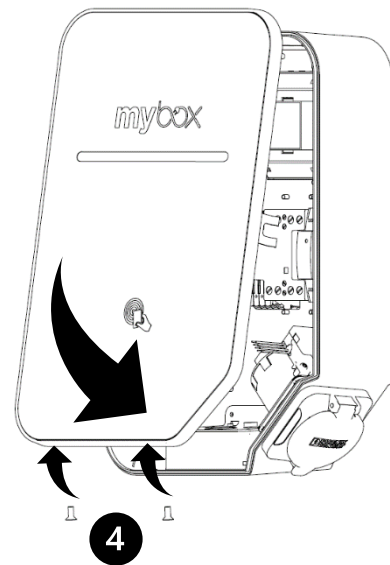

6 Settings

1. To set up the charging station, use the **MyBox mobile app**, which can be downloaded using the QR codes below.



2. Create an account by registering directly in the *MyBox* mobile app.
3. Begin the pairing process **by adding the device** using the symbol **+** and selecting the Wi-Fi or Ethernet connection method (depending on the configuration).
4. In the "device verification" window, **scan the QR code of the charging station** for pairing, or enter the device ID manually.
QR code and device ID can be found on the control unit or on the last page of the installation manual.
5. Select the Wi-Fi network with internet connection to which you want to connect the charging station.
6. Complete the process of pairing the charging station with the mobile app.

*More information for pairing the charging station with the *MyBox* mobile app can be found on our website mybox.eco*



The set-up of the device must be carried out by a professional who knows how to connect the charging station to your current wiring.

For more information on adjustable parameters or wiring examples, please visit our website.

Charging station configuration

AC modul

Parameter to be set	Description
Max-mains-curr main circuit breaker value	The setting of the main breaker value (A) needs to be entered for the dynamic power management (DLM) system
Max-cb-current breaker value for charging station	Setting the breaker value (A) for the charging station supply

OCPP protokol

Parameter to be set	Description
occp-enabled	Enabling / disabling OCPP communication
occp-evseid	OCPP charging station identifier
occp-url-cs	URL for connection with OCPP system
occp-freevend-idtag	Setting the OCPP tag for free charging Default settings: A0000000

DLM

Parameter to be set	Description
dIm-on-error	Setting the charging mode if the DLM is in an error state
PAUSE – Suspension of charging	
STOP – Charging stops	
CHARGE-AT-MIN – Min. current charging (6A)	
CHARGE – Charging with max. possible current	

SOLAR management

Parameter to be set	Description
solar-mgmt	Solar management on / off
solar-mode	Setting the solar charging mode
CHARGE-AT-MIN_WITH_OVERFLOW – Charging with min. overcurrent from solar source	
CHARGE-AT-MIN – Min. current charging (6A)	
PAUSE_NO_OVERFLOW – Suspension of charging if there is no overflow from the solar source	
solar-on-error	Charging mode setting in case the solar mode is in an error state.
PAUSE – Suspension of charging	
STOP – Charging stops	
CHARGE-AT-MIN_WITH_OVERFLOW – Min. current charging (6A)	
CHARGE – Charging with max. possible current	



WARNING! Unprofessional change of the station settings can lead to malfunction of the device and the need for intervention of a service technician. Please note this service may be chargeable, according to the terms and conditions of your charging station supplier!

How it charges

Before using the MyBox charging station, make sure that the following requirements are met:

- The product has been installed and connected to the mains by a qualified electrician according to the instructions of the installation manual.
- The charging device is correctly configured.
- Firmware is up to date (see system information in the mobile app or local interface).

Charging process

1. Before charging, check the charging cable and connector for damage or dirt, e.g. foreign objects or water ingress.

2. Connect the integrated charging cable to your electric vehicle. Charging will start and automatically adjusts to the electric vehicle and the available energy, depending on the configuration.

If the vehicle does not start charging, check that charging is activated in the vehicle and that the charging cable is correctly connected. If charging still does not start, check the charging station circuit breaker. If the circuit breaker is in the correct position - contact technical support.

RFID identification

If the charging station is equipped with RFID identification and this feature is enabled, identification will be required to start the charging process.

To be able to use the charging station's RFID security, RFID tags must first be added to the control unit using a mobile app. More information can be found on our website mybox.eco/support.

RFID tag verification process:

1. Connect the charging cable to the electric car.
2. The charging station light (white center lit) indicates the need to attach the RFID identification tag.
3. Attach the RFID tag to the RFID area on the front panel of the charging station. The light effect on the LED strip indicates, by unfolding the white color to the sides, a successful identification.
4. The charging station verifies the RFID tag and starts charging.

You can use a registered RFID tag to terminate the charging process or terminate the charging process in your electric vehicle.

Applications and local interface

Local charging station interface

The local interface is designed to set up the charging station system locally when the internet is not available.

To set up, you must connect to the charging station's local Wi-Fi network.

Network name: MyBox-Rxx + 8 symbols ID station

Password: 12345678

Login for settings

The overall device settings can be accessed using a web browser.

IP address: 192.168.4.1

Username: admin

Password: admin+first 4 symbols ID station
(for example *adminjt3d*)

MyBox Cloud

MyBox Cloud is a tool designed to manage one or more MyBox devices. This system is designed primarily for owners or operators of charging stations, installers, administrators, service personnel and other users who need to manage multiple products from one interface.

Web application MyBox Cloud is available on the web at cloud.mybox.pro

To log in to the MyBox Cloud web app, use the same login details as for the MyBox mobile app.

Mobile application MyBox

You can download the MyBox app from your iOS or Android mobile device.

The following QR codes can be used to download the app for your mobile device:



Download on the
App Store



GET
Google Play

Light signalling

Description of the traffic lights

Orange (pulsing)

Green (permanently luminous)

White (center and light effect only)

Blue (pulsing)

Blue (uninterrupted)

Red

Status

Restarting the station.

Ready to charge.

The charging station is waiting for authorization by RFID tag. Attach the RFID tag to the RFID area on the front panel of the charging station. A white light will develop from the center to the edges of the LED strip

and charging will begin.

Charging is in progress.

Charging is suspended or stopped (the vehicle is connected).

Charging station error. Switch off power supply and disconnect the charging cable from your electric car. Restart the charging station using the mobile app or by switching off and switching on the circuit breaker.

NOTICE! If the red light is still on, disconnect the charging cable, switch off the circuit breaker for the charging station and contact technical support.

The information provided in this document is for information purposes only. It is current and subject to change without notice.

ELEXIM, a.s. is not responsible for any other use of the information provided in this document.

ELEXIM, a.s. and MyBox products, product names, trademarks and slogans, whether registered or not, are the intellectual property of ELEXIM, a.s. and may not be used without its prior written consent. All other products and services mentioned may be trademarks or service marks of their respective owners.

Producer:

ELEXIM, a.s., Riegrovo náměstí 179/14, 767 01 Kroměříž, info@elexim.net

May 2023 – ver. 1.0. All rights reserved.



QR code of the charging station

used for pairing with the *MyBox* mobile app
and is a one-number identifier for this device